

ScaleViper®

WHOLE-HOUSE FILTRATION SYSTEM
Residential/Light Commercial

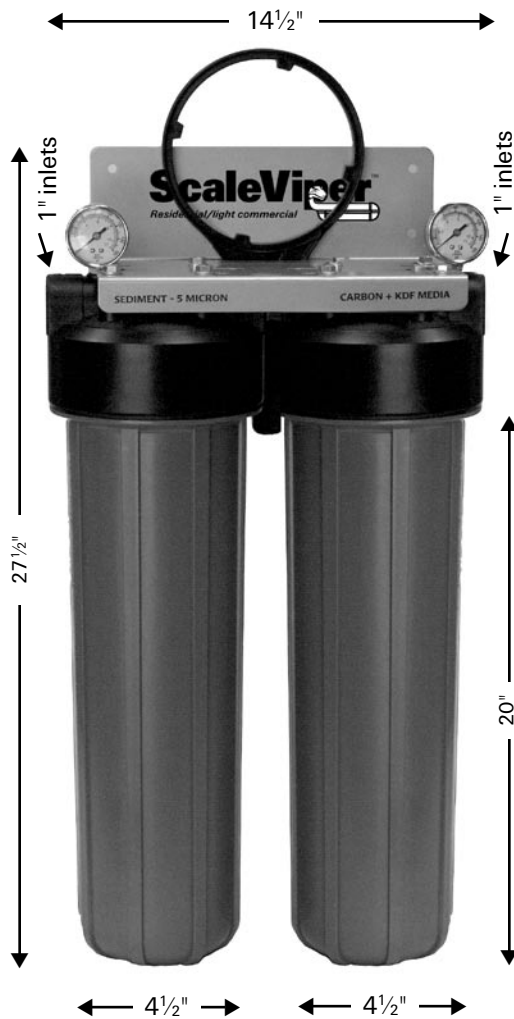

CARBON (GAC) FILTER ADVANTAGES

- Great-tasting, fresh-smelling water on demand from every tap
- Leaves healthful minerals intact, producing a tastier mineral water
- Low maintenance
- Lower operating costs than reverse-osmosis units

UNIT SIZE: 27 1/2" high, 14 1/2" wide, 8" deep
UNIT WEIGHT: 44 lbs.
INLETS are 1" NPT
FILTER CARTRIDGES: 20" high, 4 1/2" dia.

Comes with two pressure gauges, stainless steel brackets, and filter change tool. Pre-assembled and ready to install. One year warranty.
